

HONO Measurement by Coil Sampling/Azo Dye Derivatization/Long-Path Flow Cell Spectrophotometry

Xianliang Zhou

**Wadsworth Center/NYS Department of Health
School of Public Health/State University of New York in Albany**

Original HPLC Method (Zhou et al., 1999; Huang et al., 2002)

- Aqueous phase scrubbing using a coil sampler (1 mM PO₄-buffer, pH7.0)
- In-line derivatization (DNPH or SA/NED)
- HPLC separation/UV-vis absorbance detection

→~1 pptv detection limit, one data point every 5 min

Modified Flow Injection Method

- Aqueous phase scrubbing using a coil sampler (water)
- In-line SA/NED derivatization
- Flow injection analysis using a long-path flow cell spectrophotometer

→~1-3 pptv detection limit, one data point every 1-5 min

Blank Control/Interference Elimination

Using a Na₂CO₃-coated annular denuder to generate “zero” air for blank control and interference correction.

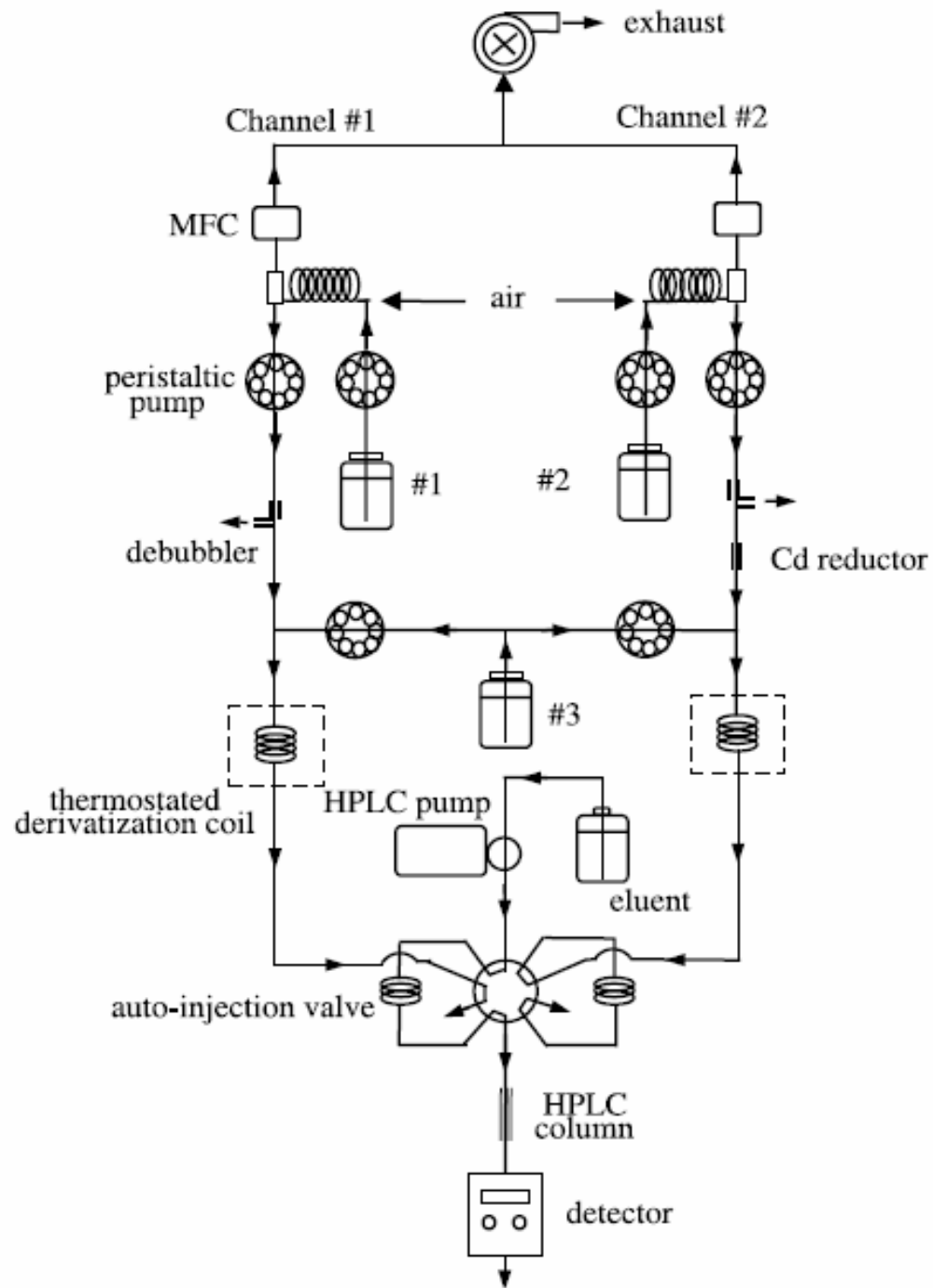

Original HPLC System
(Huang et al., 2002)

Original HPLC Method (Zhou et al., 1999; Huang et al., 2002)

- Aqueous phase scrubbing using a coil sampler (1 mM PO₄-buffer, pH7.0)
- In-line derivatization (DNPH or SA/NED)
- HPLC separation/UV-vis absorbance detection

→~1 pptv detection limit, one data point every 5 min

Modified Flow Injection Method

- Aqueous phase scrubbing using a coil sampler (water)
- In-line SA/NED derivatization
- Flow injection analysis using a long-path flow cell spectrophotometer

→~1-3 pptv detection limit, one data point every 1-5 min

Blank Control/Interference Elimination

Using a Na₂CO₃-coated annular denuder to generate “zero” air for blank control and interference correction.

Legends



3-way valve

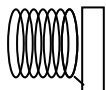

coil sampler



annular denuder



peristaltic pump

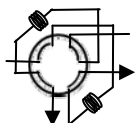

Injection valve



spectrometer



light source

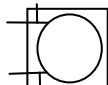

long-path flow cell



derivatization coil



air pump



debubbler



mass flow controller

Modified Flow Injection System

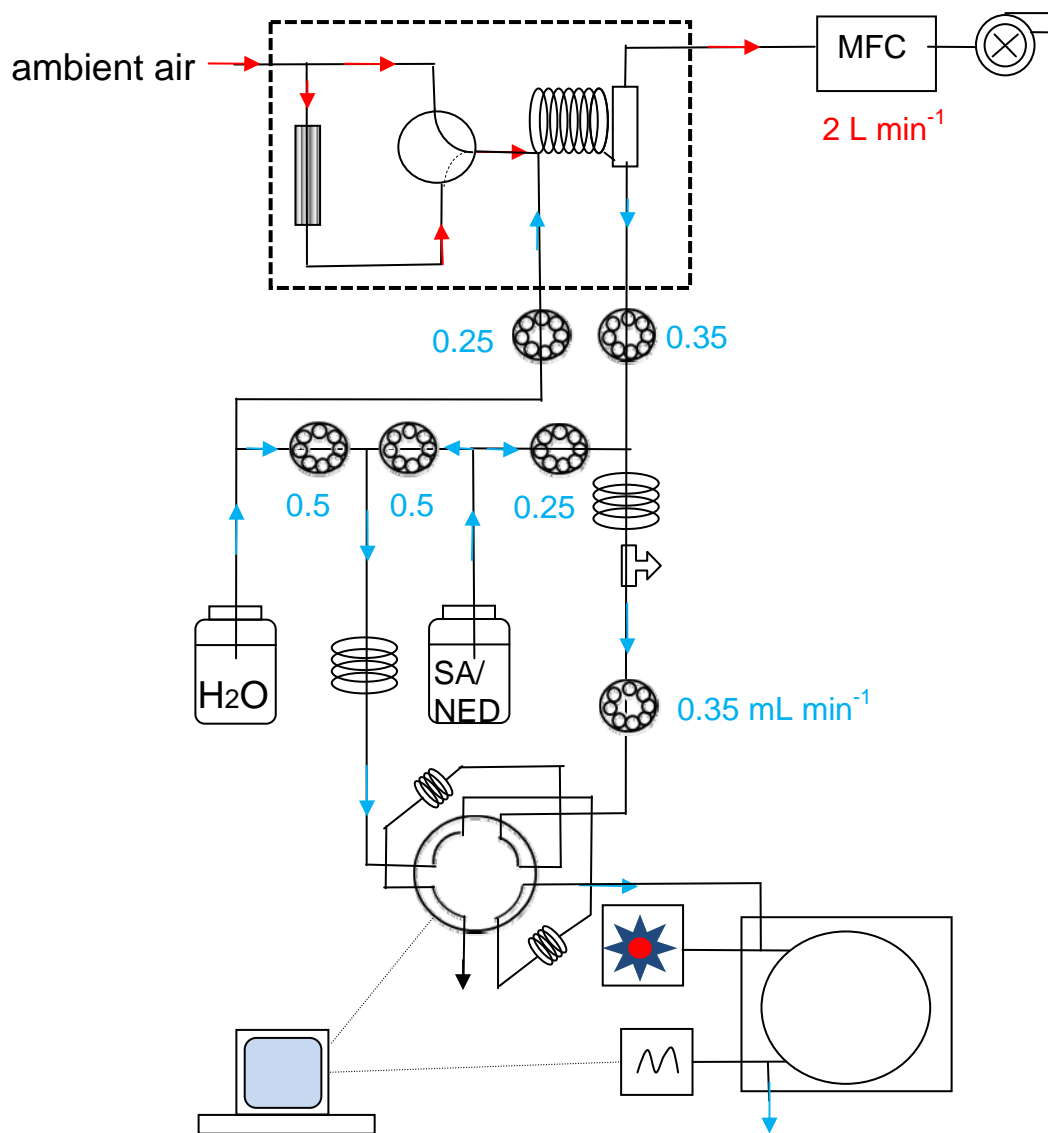

Original HPLC Method (Zhou et al., 1999; Huang et al., 2002)

- Aqueous phase scrubbing using a coil sampler (1 mM PO₄-buffer, pH7.0)
- In-line derivatization (DNPH or SA/NED)
- HPLC separation/UV-vis absorbance detection

→~1 pptv detection limit, one data point every 3-10 min

Modified Flow Injection Method

- Aqueous phase scrubbing using a coil sampler (water)
- In-line SA/NED derivatization
- Flow injection analysis using a long-path flow cell spectrophotometer

→~1-3 pptv detection limit, one data point every 1-10 min

Blank Control/Interference Elimination

Using a Na₂CO₃-coated annular denuder to generate “zero” air for blank control and interference correction.

Ambient HONO at Whiteface Mountain Lodge site, May 22, 2008

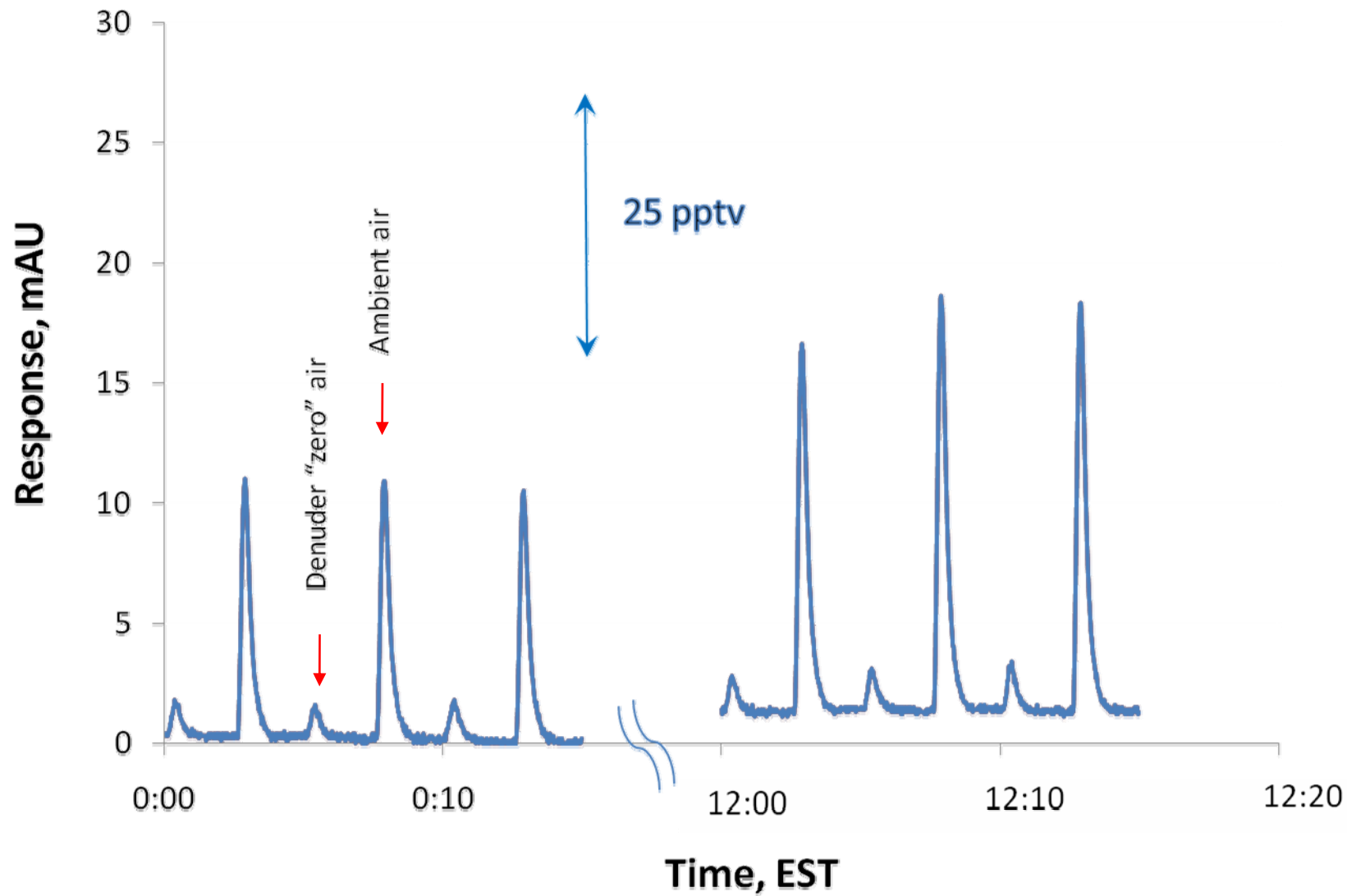

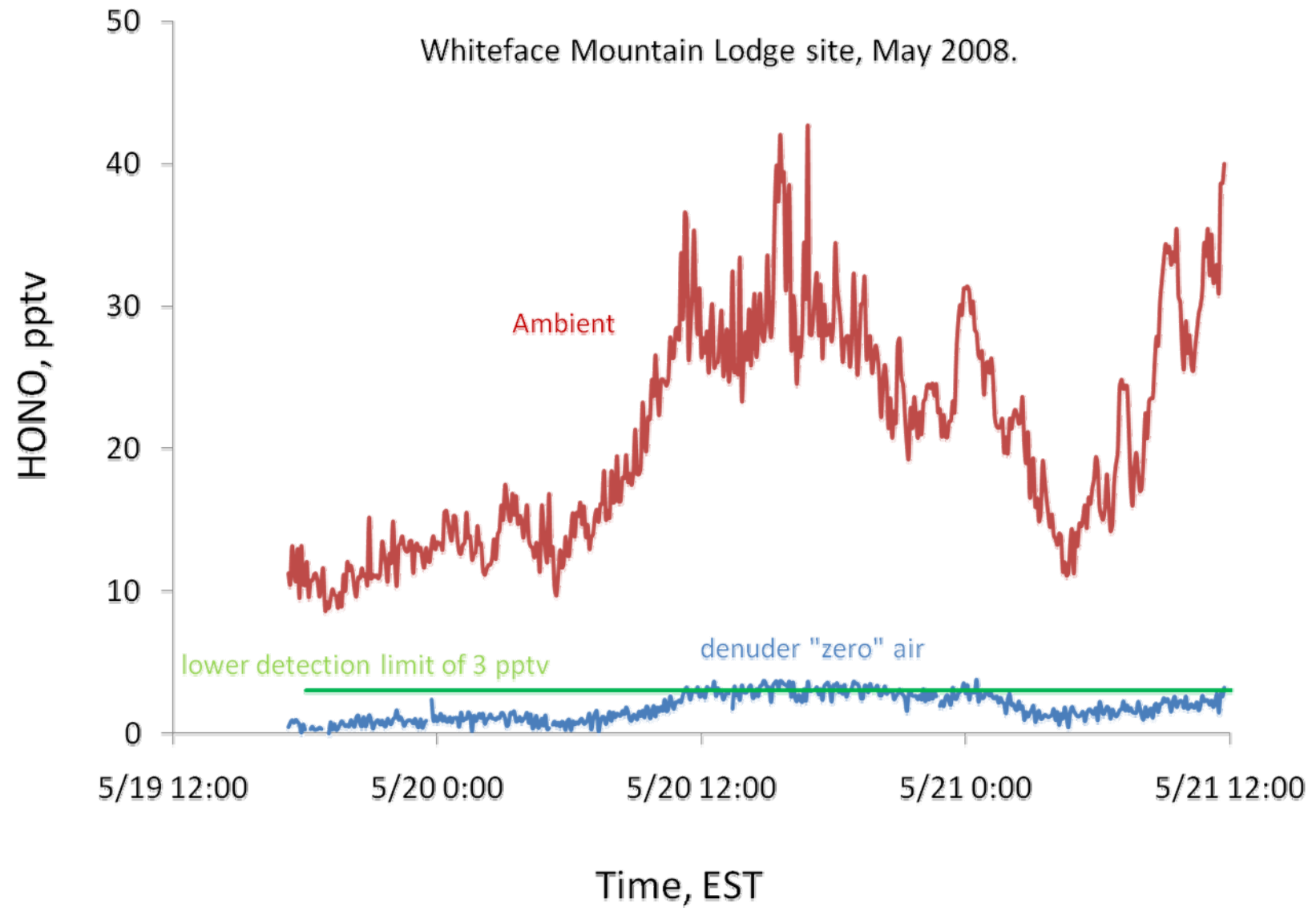

Correlation of denuder zero air HONO and ambient HONO

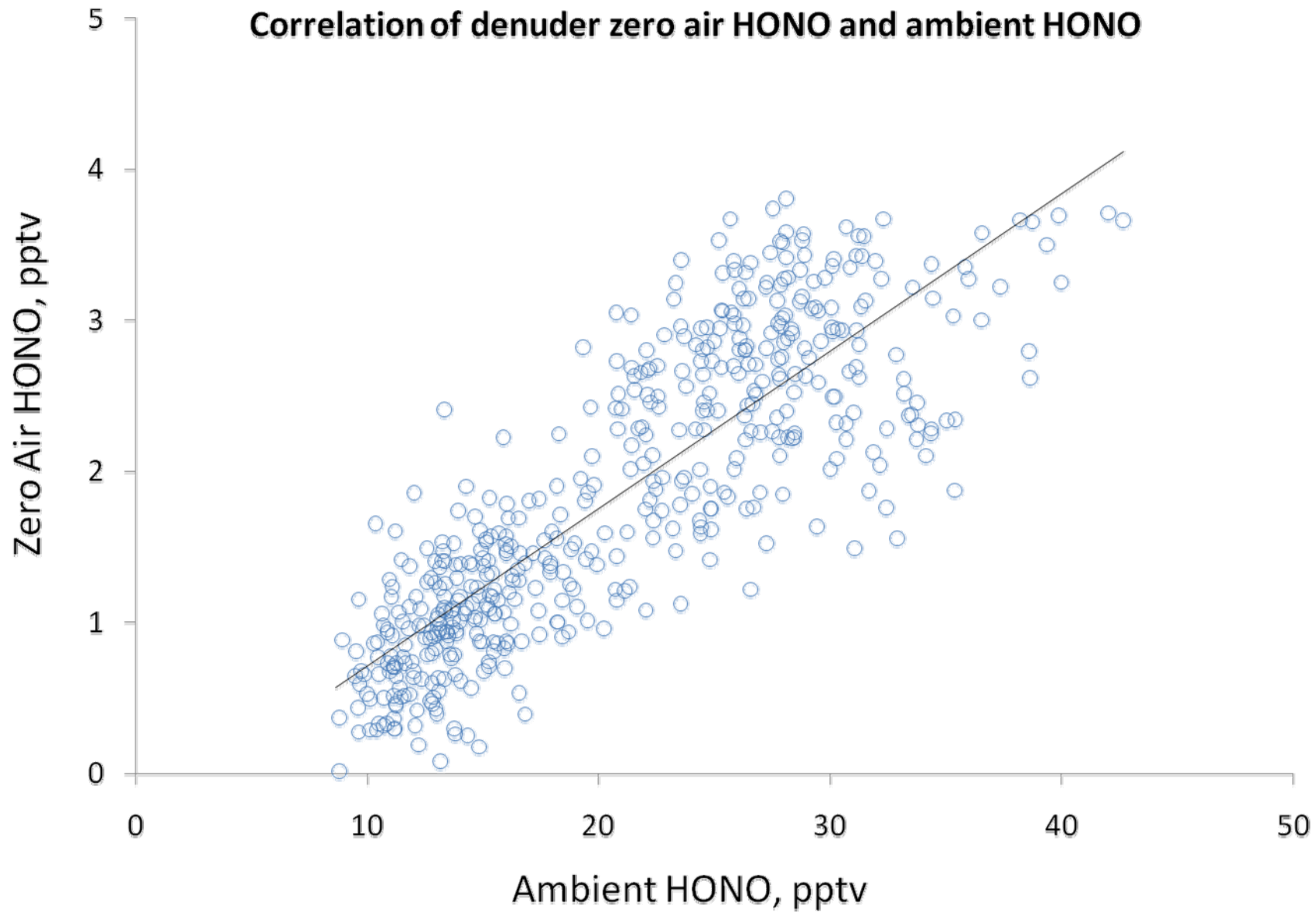

A Third Generation System Without an Injection Valve

- Aqueous phase sampling using a coil sampler, which alternately scrubs ambient air (20-25 min) and denuder “zero” air (5-10 min)
 - In-line SA/NED derivatization
 - Continuous measurement using a long-path flow cell spectrophotometer
- <2 pptv detection limit for a 2-min average from 5-second raw data
- 2-3 min 90%-signal response time
- ~20 min continues data over a 30-min cycle

Legends



valve

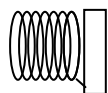

coil sampler



annular denuder



peristaltic pump



spectrometer



light source

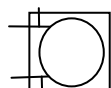

long-path flow cell



derivatization coil at 55°C



air pump



debubbler



Mass flow controller

A Third Generation System without Injection Valve

